

description

The Epic H-77 is a semi-automatic turntable style wrapping machine is designed for economical and efficient unitization of pallet loads with stretch film which has been pre-stretched. This machine can dramatically increase throughput rates and lower cost per load compared to manual (hand) stretch wrapping operations

operation

- 1) Place pallet load on turntable with forklift
- 2) Attach film to bottom of load, press start button
- 3) Load is wrapped according to set parameters
- 4) After cycle, cut film and secure tail to load
- 5) Remove wrapped pallet load with forklift

• H-77 features

- Powered prestretch film carriage elongates film 200% (standard)
- Wraps pallet loads (55" x 55" max.) weighing up to 4,000 pounds
- Automatically adjusts for various load heights (up to 82" maximum)
- Variable turntable rotation speed with a maximum of 12 RPM
- Forklift portable base design for easy machine transport
- All structural steel construction for years of dependable service
- 4-point caster turntable support system is rugged and maintenance-free
- Non-proprietary replacement parts can be purchased locally or from dealer
- Self-threading Insta-Thread™ LT carriage makes loading film fast, safe and easy
- Revo-Logic™ technology assures precise number of top/bottom wraps
- Adjustable film roping bar for strong interlocking of load to pallet

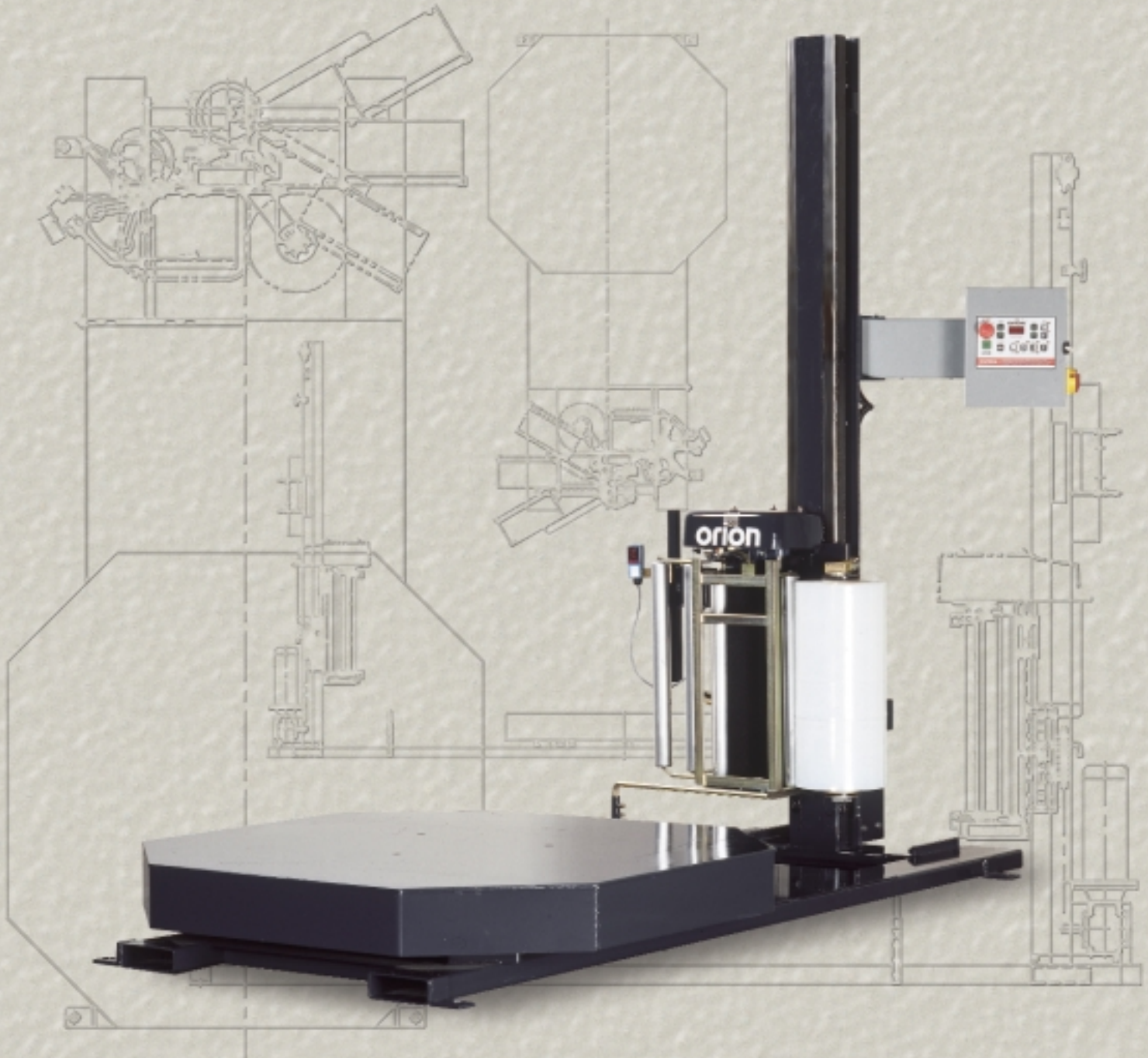

Insta-Thread™ LT Film Delivery System: Fast, Easy, Consistent



Threading the Insta-Thread LT film carriage is fast and easy: simply open the hinged roller frame, pull the film across, then close and latch the frame. That's it!

The H-77 uses the Insta-Thread™ LT film delivery system is an extremely reliable film carriage engineered to accurately pre-stretch film at a fixed rate and deliver it to the load at a constant tension level.

- Uses standard 20" stretch film rolls
- Specially texture-belted pre-stretch rollers for accurate and consistent film yield
- 200% standard pre-stretch ratio for economical operation
- Carriage lifted by heavy-duty ANSI industrial chain
- Revo-Logic™ exact wrap count technology eliminates film waste by applying top & bottom wraps precisely
- Electronic film tension control on control panel
- Variable speed film output for even tension on corners
- Heavy-duty ANSI chain & sprocket ratio control
- Multi-point UHMW precision carriage guidance system



Controller: Non-proprietary, Easy to Use, UL, NEMA-12

- CSA Approved, UL Approved, NEMA 12 rated control panel
- Micro-switch keypad is easy to understand and operate
- Large mushroom-style Emergency E-Stop button
- Electronic film tension control on keypad
- State-of-the-art logic control
- Separate count settings for top wraps & bottom wraps
- Separate settings for carriage up speed & carriage down speed
- Raise & lower film carriage manually with the Carriage Jog button
- Pause the wrap cycle without resetting with Cycle Pause button
- Rotate the turntable manually with the Turntable Jog button
- Wrap Up Only key allows for uni-directional wrap mode



distributed by:

ORION Orion Packaging Systems, Inc.
 A Pro Mach Operating Partner
 USA Corporate Headquarters
 100 Crescent Drive
 Collierville, TN 38017
 Toll Free (800) 333-6556
 Telephone (901) 888-4170
 Fax (901) 365-1071
 CANADA Manufacturing
 2270 Industrial Blvd
 Laval, Montreal, H7S 1P9
 Telephone (450) 667-9769
 Fax (450) 667-6320
 Email: sales@orionpackaging.com
 Web: www.orionpackaging.com
 Bulletin #H77.10/00.JKG

Turntable Drive & Support: Heavy-Duty, Easy to Maintain

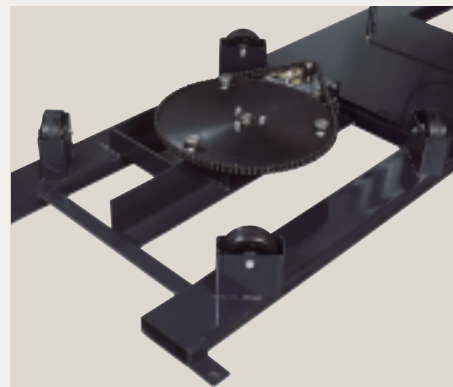

- Heavy-duty ANSI chain & sprocket direct drive
- 4-point caster support system offers superior performance if load is placed off-center
- Variable speed drive motor: 0-12 RPM
- Positive home position alignment
- Non-proprietary replacement parts
- All components easily accessible
- Adjustable soft-start and stop (gradual acceleration / deceleration)

H-77 specifications

Machine Performance	
Rotation speed	Variable to 12 RPM
Film Delivery System	
Prestretch ratio	200% (standard)
Threading method	Insta-Thread LT
Corner compensation	Electronic
Load Specifications	
Maximum load weight	4,000 pounds
Maximum load size	55"W x 55"L x 82" H
Power Requirements	
	115 / 1 / 60 15 amp
Structural Design	
	100% Structural steel used throughout
	Portable after initial installation
	Structural steel tube mast
	Hinged mast for easy shipping & transport
Warranty	
	3/5 Year limited
Estimated Shipping Weight	
	1,100 pounds

H-77 dimensions

